

F R E E M A N

205 Viger West, Suite 207
 Montreal, Quebec, Canada H2Z 1G2
 Ph: 514-868-6666 • Fax: 514-394-2667
 freemanmontrealES@freemanco.com

**DISCOUNT PRICE
 DEADLINE DATE
 OCTOBER 18, 2011**

**INCLUDE THE FREEMAN METHOD OF
 PAYMENT FORM WITH YOUR ORDER**

NAME OF SHOW: **CANADIAN WASTE & RECYCLING EXPO / NOVEMBER 9-10, 2011**

COMPANY NAME _____ BOOTH #: _____

CONTACT NAME: _____ PHONE #: _____

E-MAIL ADDRESS _____

For Assistance, please call 514-868-6666 to speak with one of our experts.

For fast, easy ordering, go to www.myfreemanonline.com

All Exhibits Include: Installation & Dismantle of Exhibit
 Material Handling of Exhibit
 Classic Carpet with Nightly Vacuuming
 2 Halogen Spots (per 10' unit)

To place your order, please check the appropriate box and complete the remaining selections at the bottom of the form.

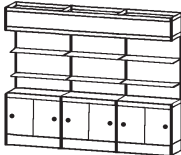
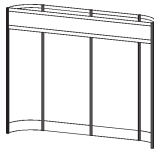
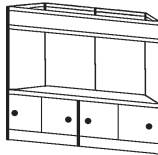
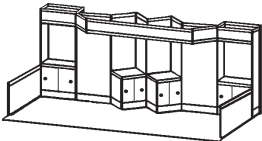
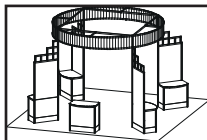
PACKAGES	A. FREE STANDING COUNTER Discount Price 990.00 Standard Price 1,287.00 <input type="checkbox"/> Part# 1710201 	B. CURVED BACK WALL EXHIBIT Discount Price 625.00 Standard Price 812.50 <input type="checkbox"/> Part# 1710300 	C. BACK WALL COUNTER EXHIBIT Discount Price 940.00 Standard Price 1,222.00 <input type="checkbox"/> Part# 1710400 
	E. 10' x 20' ANGLED EXHIBIT Discount Price 2,570.00 Standard Price 3,341.00 <input type="checkbox"/> Part# 1710600 	F. 20' x 20' ISLAND EXHIBIT Discount Price 4,410.00 Standard Price 5,733.00 <input type="checkbox"/> Part# 1710800 	
	PACKAGES		

- Orders received after the deadline date or without payment will be charged the Standard Price and are subject to availability.
- Orders cancelled after production begins are subject to a 100% Cancellation Charge.

CHOOSE YOUR PANEL

- BLUE FABRIC GRAY FABRIC
 BLACK FABRIC WHITE HARDWALL

CARPET

Our Classic Carpet and nightly vacuuming are included in the price of your Rental Exhibit. The following colors are available.

Check color choice

- Blue Red Grey Black

You may upgrade your carpet to one of our 15 designer colors in our PRESTIGE carpet line. Now available in **28 oz.** and **40 oz.** weight. Refer to our enclosed Carpet order form for color selections and pricing.

LIGHTING

Each Rental Exhibit includes 2 Arm Lights (per 10' unit).
 Note: Electrical power must be ordered using the electrical order form included in your service manual.

- * Electrical power and labor to install lights must be ordered separately
- * Custom graphics must be ordered separately

HEADER IDENTIFICATION SIGN

Indicate which color lettering you would like. We have a wide variety of standard colors available:

Letter color desired: _____

Indicate exactly how you want your company name to appear:

CONTACT FOR PRICING

Please check any of the following boxes to have an Exhibitor Sales Specialist contact you for pricing:

- Upgrade Carpet
 Custom Logo Header
 Creating a Custom Exhibit

TOTAL COST	
Sub-Total _____ + 5% GST _____ = Sub-Total _____ + 8.5% _____ = TOTAL _____	

FREEMAN exhibit packages

F R E E M A N

205 Viger W., Suite 207
 Montreal, Quebec H2Z 1G2
 514-868-6666 • Fax: 514-394-2667
 FreemanMontrealES@freemanco.com

**DISCOUNT PRICE
 DEADLINE DATE
 OCTOBER 18, 2011**

**INCLUDE THE FREEMAN METHOD OF
 PAYMENT FORM WITH YOUR ORDER**

NAME OF SHOW: **CANADIAN WASTE & RECYCLING EXPO / NOVEMBER 9-10, 2011**
 COMPANY NAME _____ BOOTH #: _____
 CONTACT NAME: _____ PHONE # _____
 E-MAIL ADDRESS _____

For Assistance, please call 000-000-0000 to speak with one of our experts.

For fast, easy ordering, go to www.myfreemanonline.com

TABLE TOP UNIT



Rental Units Include:
 Draped Table (Select color below)
 Classic Carpet 10' X 10' (Select colour below)
 Installation & Dismantle of Exhibit
 Material Handling of Exhibit
 Nightly Vacuuming
 1-200 Watt Halogen Light (Electrical service & labour not included)

Purchase Units Include:

1-Case
 One Time Installation & Dismantle

Header Identification Sign - (white with black text) Indicate copy below:

RENTAL	QTY.	TOTAL
Size	Price	
40" H x 6' W	\$605.00	_____
40" H x 8' W	\$665.00	_____

PURCHASE*

Size	Price	
40" H x 6' W	\$1,080.00	_____
40" H x 8' W	\$1,215.00	_____

*Shipping Not Included

Fabric Panel Colours for All Units: Black Grey
Additional Fabric Panel Colours for Purchase Units Only:
 Blaze Red Blueberry Emerald Silver
Other Colours Also Available for Purchase Units
10'x10' Classic Carpet: Blue Black Grey Red

Table Drape:
 Black Blue Burgundy Green Gold Grey
 Plum Red Teal White

FLOOR UNIT

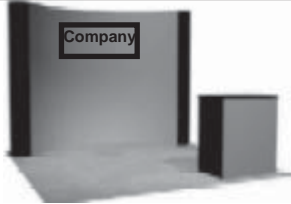

Rental Units Include:
 Classic Carpet 10' X 10' (Select colour below)
 Installation & Dismantle of Exhibit
 Material Handling of Exhibit
 Nightly Vacuuming
 1-Podium - 8'H x 10'W unit only
 2-200 watt Halogen Lights (Electrical service & labour not included)

Purchase Units Include:

2-Cases
 One Time Installation & Dismantle
 1-Podium - 8'H x 10'W unit only

Header Identification Sign - (white with black text) Indicate copy below:

RENTAL	QTY.	TOTAL
Size	Price	
8' H x 8' W	\$795.00	_____
8' H x 10' W	\$855.00	_____

PURCHASE*

Size	Price	
8' H x 8' W	\$2,445.00	_____
8' H x 10' W	\$2,830.00	_____

*Shipping Not Included

Fabric Panel Colours for All Units: Black Grey
Additional Fabric Panel Colours for Purchase Units Only:
 Blaze Red Blueberry Emerald Silver
Other Colours Also Available for Purchase Units
10'x10' Classic Carpet: Blue Black Grey Red

CUSTOM GRAPHIC / PHOTO PANELS

Our custom graphic panels can dramatically enhance your exhibit's appearance.

Please check the box to have an Exhibitor Sales Specialist contact you to assist in creating a unique exhibit.

OPTIONAL ACCESSORIES	RENTAL	PURCHASE	TOTAL
Part #	Description	Qty.	Price
1715800	2-200 Watt Halogen Light Kit	_____	\$170.00
1715801	1-200 Watt Halogen Light Kit	_____	\$110.00
1715802	Straight Shelf	_____	\$ 91.00
1715803	Angle Shelf	_____	\$ 91.00

QUICK TIPS

- If shipping literature or products, material handling rates will apply.
- Order in advance to save time, money and ensure availability. **Orders received after the deadline date or without payment will cost an additional 30% over prices indicated.**

PURCHASE UNITS TOTAL COST	
Sub-Total _____	+ _____ + _____ = TOTAL _____
	5% (GST) 8.5% (PST)

RENTAL UNITS TOTAL COST	
Sub-Total _____	+ _____ + _____ = TOTAL _____
	5% (GST) 8.5% (PST)